

Hollow core bit – lightweight design with internal thread M16

The lightweight core bit convinces with its user-friendly details – easy, fast and clean drilling. Thanks to the specially developed asymmetrical tooth geometry, it is ideal for working in masonry natural stone and calcareous sandstone.



Hollow core bit – lightweight design system



The lightweight core bit can be used with SDS-plus adapter for rotary hammer drills up to 4 kg, with hexagon adapter for heavy hammer drills with 3-jaw chuck.



DIAMETER MM	TOTAL LENGTH MM	ITEM NO.
30	50	7072
35	50	7073
40	50	7083
45	50	7074
50	50	7075
65	50	7077
68	50	7078
80	50	7079
82	50	7080
90	50	7081
100	50	7084

Asymmetrical tooth arrangement produces different impact patterns of the teeth, resulting in higher efficiency and faster drilling progress.

Increased carbide tip protrusion and chamfer on the toothed crown prevent jamming of the drill bit in the drilled hole.



Sharp tooth cutting edge geometry for extremely fast drilling progress and clean drilled holes.

Centering drill bit for easy, precise spot drilling.



The use of high-quality alloy steel in combination with state of the art hardening and soldering techniques as well as specialized surface treatment produces a high quality, robust professional tool.

Solid brick	***
Aerated concrete	***
Lime sandstone	***
Hollow hole brick	**

Materials
The lightweight design of hollow core cutter can be used in many different materials such as solid brick, aerated concrete, lime sandstone and hollow hole brick.



Ташев Галвинг ООД
www.tashev-galving.com

Accessory hollow core cutter, lightweight design Combi adapter

Adapters available in various lengths and shanks allow flexible and economical use of the system.

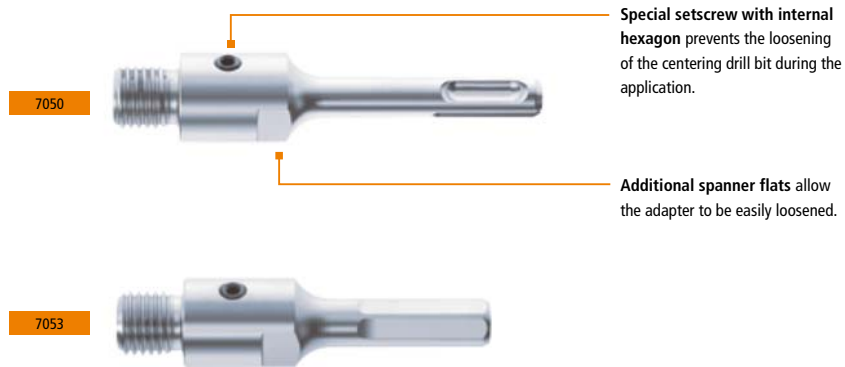

DESCRIPTION	TOTAL LENGTH MM	ITEM NO.
SDS-plus combi adapter with M16 thread	105	7050
SDS-plus combi adapter with M16 thread	220	7051
SDS-plus combi adapter with M16 thread	370	7052
Hexagon combi adapter with M16 thread	90	7053
Hexagon combi adapter with M16 thread	220	7054
Hexagon combi adapter with M16 thread	370	7055

Centering drill bit with spanner flats

DIAMETER MM	TOTAL LENGTH MM	ITEM NO.
8	120	70250



Hex-wrench key,
SW 3,0 mm
angled



ROTARY